

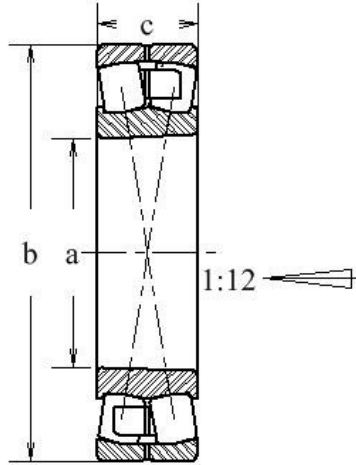

223 Spherical Roller Bearing

Tapered Bore



•Two Rows of large diameter, super-finished rollers

•Heavy bronze cages

•Standard W-33 relubrication

Bearing No.	Bore A (mm) (in.)	Outside Diameter B (mm) (in.)	Width C (mm) (in.)	Max Fillet Radius (mm) (in.)	Basic Static Load (lbs.)	Basic Dynamic Load (lbs.)	Weight (lbs.)	Limiting Speed (rpm)
22308K	40 1.5748	90 3.5433	33 1.2992	1.0 0.039	27800	25800	2.34	5500
22309K	45 1.7717	100 3.970	36 1.4173	1.0 0.039	35300	32600	3.09	4900
22310K	50 1.9685	110 4.3307	40 1.5748	1.0 0.039	45700	40300	4.12	4400
22311K	55 2.1654	120 4.7244	43 1.6929	1.5 0.059	51000	45800	5.11	4100
22312K	60 2.3622	130 5.1181	46 1.8110	1.5 0.059	57700	51600	6.53	3800
22313K	65 2.5591	140 5.5118	48 1.8898	1.5 0.059	64800	56500	8.91	3500
22314K	70 2.7559	150 5.9055	51 2.0079	1.5 0.059	75100	65400	9.55	3200
22315K	75 2.9528	160 6.2992	55 2.1654	1.5 0.059	91700	75300	11.84	3000
22316K	80 3.1496	170 6.6929	58 2.2835	2.0 0.079	105100	86200	14.15	2800
22317K	85 3.3465	180 7.0866	60 2.3622	2.0 0.079	115400	93900	16.50	2700
22318K	90 3.5433	190 7.4803	64 2.5197	2.0 0.079	122700	97200	19.07	2500
22319K	95 3.7402	200 7.8740	67 2.6378	2.0 0.079	141500	113700	22.62	2400
22320K	100 3.9370	215 8.4646	73 2.8740	2.0 0.079	164300	132100	28.66	2200
22322K	110 4.3307	240 9.4488	80 3.1496	2.0 0.079	211100	167100	44.91	2000
22324K	120 4.7244	260 10.2362	86 3.3858	2.0 0.079	239600	189400	52.91	1900
22326K	130 5.1181	280 11.0236	93 3.6614	2.5 0.098	278600	212500	63.71	1700
22328K	140 5.5118	300 11.8110	102 4.0157	2.5 0.098	332200	254700	79.37	1600
22330K	150 5.9055	320 12.5984	108 4.2520	2.5 0.098	373300	284600	96.12	1500